

Standard Solar Cell



7- SSC Series of standard solar cell

Features

- Photovoltaic cells of standard solar cell 2cmx2cm with monocrystalline silicon or polycrystalline silicon (can be customized based on need from users)
- The cells with uniform surface and good stability will be sealed in a vacuum package after time aging and screening.
- Solar battery will be set on the center of the square aluminum base and is equipped with a glass window for radiation protection. The seal package for the window will be with good transparency and photosensitive glue with a similar refractive coefficient.
- Below the solar cell, a platinum resistance temperature sensor Pt100 has been installed and It is demarcated before packaging.
- Kelvin connection mode with four output ports for the solar cell and a temperature sensor.

Models	Products
7-SSC10	Standard monocrystalline silicon solar cell
7-SSC20	Standard polycrystalline silicon solar cell

7-SCT1 Solar Cell IV Measurement Platform with temperature control

The Special measurement platform not only can be used together with the solar simulator, but also can be applied to the QE/IPCE test.

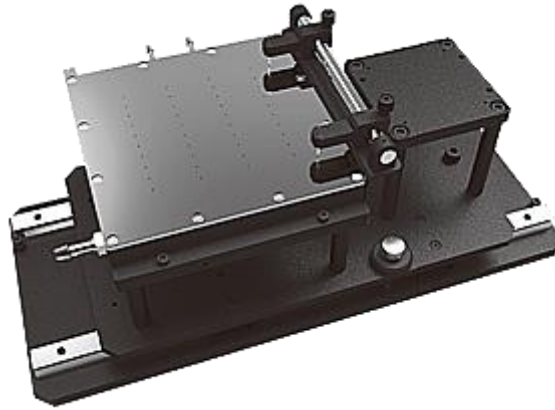

Structures of the platform: High precision positioning sliding mechanism, semiconductor temperature control platform, standard cell etc.

Characteristic.

1. Unique precision positioning mechanism, It is convenient to make handover and position for the parts measured and standard parts.
2. Semiconductor constant temperature, measurement platform with changeable temperature, temperature range: 5-40 °C, ± 0.1 °C
3. Copper surface on the platform with high-quality and high conductivity, size 160mm \times 180mm (can be customizable), can cover up to heat insulation film.
4. Sinking groove arranged for the installation of surface of the platform, movable test probe (detachable)
5. Standard cell with high quality (monocrystalline silicon and polysilicon are optional, with test data or test certificate)
6. Testing accessories of solar cell can be installed
7. Optional vacuum adsorption

7-SCT2 Solar Cell IV Measurement Platform with temperature control

The Special measurement platform not only can be used together with the solar simulator, but also can be applied to the QE/IPCE test.

Structures of the platform: High precision positioning sliding mechanism, watered cycle temperature control platform, standard cells etc.

Characteristic.

- Unique precision positioning mechanism, It is convenient to make handover and position for the parts measured and standard parts.
- Watered cycle measurement platform with changeable temperature, temperature range: 5-40°C, ± 0.1 °C
- Copper surface on the platform with high-quality and high conductivity, size: 160mm × 180mm (can be customizable), can cover up to heat insulation film.
- Standard cell with high quality (monocrystalline silicon and polysilicon are optional, with test data or test certificate)
- With vacuum adsorption

7-SCF Accessories of solar cell test

7-SCF01 Moveable mount of the probe

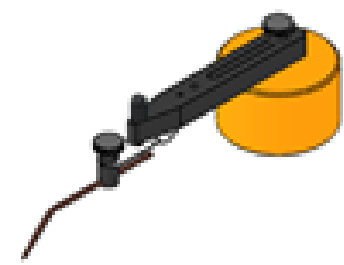

Features: Easy and convenient to use, It can be placed in any position, and to adjust the height of the probe through the adjusting knurled screw. And under its own gravity, electrode will be compacted. The position of the probe can be adjusted by the aid of the functions of adjustable length and the direction of extension.

7-SCF02 Moveable mount of the probe

Features: Easy and convenient to use, It can be placed in any position, and under its own gravity, electrode will be compacted. The position of the probe can be adjusted by the aid of the functions of adjustable length and the direction of extension.



7-SCF03 Closed test platform (It is customized according to the needs from the user)

Features: suitable for organic solar cell which is easy to decompose, closed test platform and equipped with ultraviolet quartz window. It will be filled with nitrogen to extend life of the cell. In doing this cell performance will be not changed in testing. The test platform will send the signal through a standard BNC interface and the platform is provided with a plurality of switch, convenient to output different signal electrode.

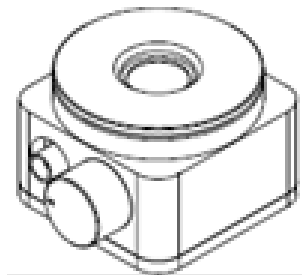

7-SCF04 Sliding probe

Features: It is suitable for the solar cell with a electrode and the photosensitive surface of the opposite side, when not in use the probe can be removed and convenient to place other forms of cell and use.

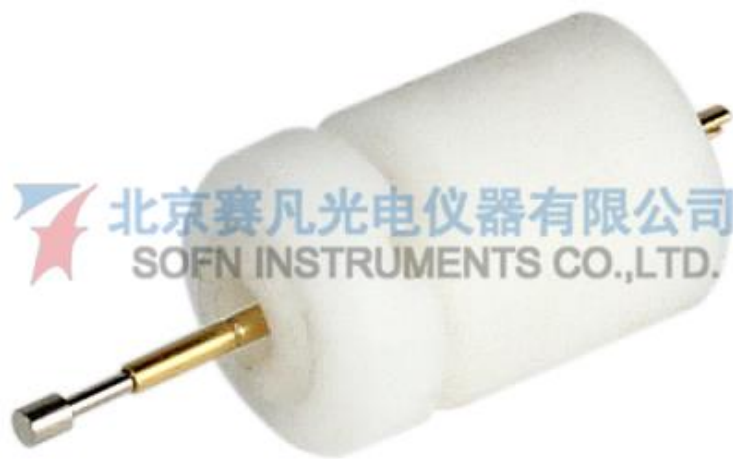

▲7-SCF04

7-SCF05 The Clamp of The Dye Sensitized Cell

Features: It is suitable for dye-sensitized solar cell , coplanar electrode or opposite side. The joint of banana valve is connected to signal, adjustable distance of electrodes.

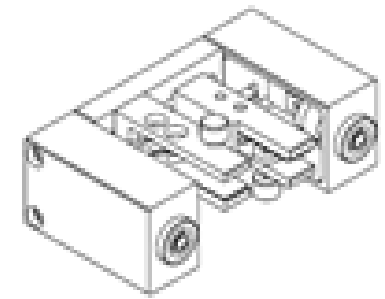

7-SCF06A/B Three Dimensional Probe (Left / Right)

Features:

It can be with three-dimensional fine-tuning, the adjustment range of each dimension is 13mm, The joint banana valve is connected to signal, left and right hand can be used in pairs, and also two pairs can be centripetal configured.

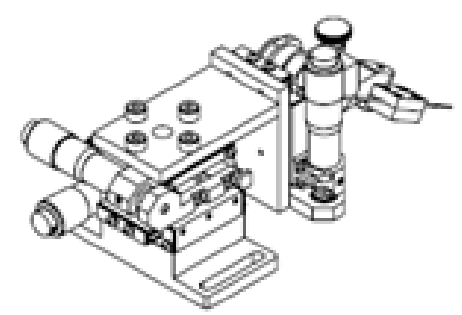

7-SCE500 Photoelectric Chemical Solar Cell Testing Instrument

SoFn Instruments Co. recently developed this new integrated instrument used in the spectroscopic applications. In the traditional field of electrochemistry, the the spectral factors is introduced to the instrument. In the research field of the solar cells, It is an important equipment at advance research in the laboratory stage for a thin film solar cell and dye sensitized solar cell.

Features of the product:

- The high power illumination from a xenon lamp
- Optical slitting system patented for eliminating multi spectrum, monochromatic light with high purity
- Full -new optical system for spectro-electrochemical designing
- Integrated structure for an integration of an electrochemical workstation and spectral analysis instrument
- Equipped with a standard detector, It can measures energy density of monochromatic light
- Application software for spectro-electrochemical field by independent developed and the operation is more convenient, more easy to expand functions.
- Parameters of measurement.
- I / V curve, I/T curve and V/T curve under the monochromatic light
- Spectrum response curve (photocurrent)